



ChemTech

International Journal of ChemTech Research

CODEN (USA): IJCRGG, ISSN: 0974-4290, ISSN(Online):2455-9555
Vol.12 No.02, pp 119-130, 2019

Evaluation of combustion analysis for various fuel injection timings with bio-diesels

I.J.Isaac Premkumar* and R.Loganathan

^{1*}Mechanical Engineering Department, V.S.B College of Engineering Technical Campus, Coimbatore – 642 109, Tamilnadu, India

Abstract : In the valuation of compression ignition engine, the effect of fuel injection timings on combustion analysis aspects were inspected in a Kirloskar DM10 category engine using Pongamia, Soya bean and Rice bran methyl esters. The different biodiesel properties were analysed and found the fatty acid contents in the different methyl esters. The GC/MS test results were utilized to found the base peak chromatogram with retention time. The different biodiesel blends were practised with diesel engine and carried out the suitable fuel and blends. The shim concept of tiny metal leafs had been used to added and removed from the timings gears and varied the injection crank angle positions. The 9^o Crank angle degree position was varied from the standard injection timings and carried the effects of combustion cylinder pressure with advanced and retarded fuel injection timings. The advancement of injection timing had higher in combustion rates using higher blends of Pongamia methyl ester. The retardment of injection timing has lower combustion rates compared to standard and advancement positions by various oil methyl ester blends. Optimum injection timings with suitable biodiesel blends had produced better hopeful outcomes compared to other oil methyl esters with the blend ratios of 10%, 30% and 50%..

Keywords : Compression ignition engine; Retardment injection timing; Advancement injection timing; Combustion; Pongamia methyl esters.

Introduction

The compression ignition engines are the most favoured in universal sectors like transport, agriculture, power generation and industry. Generally diesel engines have unique characteristics such as combination of higher torque capability, higher durability and reliability, higher fuel conversion efficiency while compared to petrol engines [1]. The development process is accepted to plan at enhancing the diesel and Otto combustion cycle process using alternative combustion modes [2]. The premixed charge combustion engines have lower thermal efficiency because of unavoidable throttling position at intake and avoidable engine knocks at 40%

I.J.Isaac Premkumar *et al* / International Journal of ChemTech Research, 2019,12(2): 119-130.

DOI= <http://dx.doi.org/10.20902/IJCTR.2019.120216>

load. The injection timing determines the condition of air in which the fuel is injected in compression ignition engine. The air temperature and pressure factors were lesser which enhances the ignition delay on the time of advanced fuel injection timings [3,4]. But advancement of injection timing position ensures the sufficient time for highly viscous fuel evaporation thereby increases the premixed combustion phase. The main disadvantage of entry of ethanol oil in direct fuel injection of diesel engine increases several difficulties similar to carbon deposition on valve seating, combustion chamber cylinder walls, increased viscosity of fuel and low volatility, poor fuel atomization and it above all direct to improper combustion. An energetic relative investigation was declared with Karanja, Jatropha and Polanga methyl esters to assess its combustion quality in direct fuel injection system [5,6]. Biodiesels were blended to diesel in percentages of B20 and B50 with different load measurements and practiced in compression ignition. The consequences of efficient Polanga methyl esters exhibited that greatest pressure in the ignition chamber while combustion process takes place. The short duration of ignition delay was happened in Jatropha methyl esters with increases the loads as well as related developments were occurred in Polanga and Karanja methyl esters [7,8]. The characteristics of Combustion analysis were identical to fuel of diesel and some small corrections in contribution factors such as engine compression ratio and fuel injection timings [9,10]. The input factors of the engine modifications were proved the significant effects of improvement in combustion. The various test output factors of the engine speed, engine load and usually observed that with improves in biodiesel blend proportions [11,12]. The maximum pressures of combustion factors have decreased while reduce within the phase of ignition delay.

In the current research analysis, Fatty acid methyl esters were prepared from soya bean, rice bran and pongamia oil through transesterification procedure. Various blends of B5, B10 and B15 were added with diesel and evaluated the combustion aspects. The timing gears were changed as 9° Crank Angle Degree (CAD) positions of advancement and retardment with assist of shim. The crank angle positions were inspected with different blends of fuel with different load measures. At advanced injection timing, the effects of Pongamia oil (PO) methyl esters had more suitable for high blends of combustion aspects compared to other fuels of Soya Bean Oil (SBO) and Rice Bran Oil (RBO) methyl esters. The proper injection timings and the suitable biodiesel blends were analysed with the positive improvement of combustion factors.

2. Materials and methods

2.1 Biodiesel preparation and Fatty acids

Mono alkyl methyl esters extracted from PO, RBO and SBO methyl esters through transesterification practice wherein crucial alcohol modifies the triacylglyceride into glycerol and three methyl esters of methyl alcohol. The methyl alcohol was taken in separately in conical flask and heated to preserve the temperature range between 55°C- 65°C. The 100 ml quantity of methanol was poured into the each oil with addition of 1.2 grams of Potassium hydroxide and few drops of hydrochloric acid [12,13]. The magnetic stirrer was utilized to stir continuously to form potassium methoxide solution and combined with SBO, RBO and PO in narrowed flask. The entire blends were sustained in the temperature about 65°C. The methanolysis effects in a rotating operative for 2 hours along with golden colour biodiesel were displaced to separator. The extracted biodiesels were cleaned with 5% distillation water which helps to remove the impurities of mixture and dust particles that fact are deposited under the separator [14, 15]. The properties of SBO, RBO and PO methyl esters are specified in Table.1 and a variety of fatty acids (FA) present in SBO, RBO and PO methyl esters were scheduled in Table 2. These all methyl ester fatty acids were identified through Gas chromatograph/ Mass spectrum JOEL Mate II.

Table 1. Different Assets of SBO, RBO and PO blend ratios

S.No	Properties of diesel and biodiesel blend ratios	Flash Point (°C)	Fuel Density (kg/m ³)	Kinematic Viscosity (at 104 Fahrenheit)	Cetane rating	Heat of combustion (kJ/kg)
1	Diesel	60-80	0.833	1.91-4.1	45	42000
2	SBO (B5)	70	0.808	2.10	56	41580
3	SBO (B10)	73	0.812	2.14	54	40950
4	SBO (B15)	75	0.826	2.20	51	39950
5	RBO (B5)	70	0.812	2.20	56	41640
6	RBO (B10)	72	0.819	2.14	55	40530
7	RBO (B15)	75	0.825	2.21	52	39500
8	PO (B5)	71	0.804	2.00	54	41540
9	PO (B10)	73	0.814	2.02	56	40370
10	PO (B15)	75	0.827	2.15	57	40270

Table 2. Different fatty acids in SBO, RBO and PO Methyl esters

S.No	Name of the oil methyl esters	Acids						
		Palmitic	Palmitoleic	Linolenic	Arachidic	Stearic	Linoleic	Oleic
1	SBO	18.2	-	0.3	0.9	18.8	18.1	44.9
2	RBO	17.9	0.25	36.2	-	2.4	1.9	40.9
3	PO	11.62	-	-	-	7.59	16.84	52.68

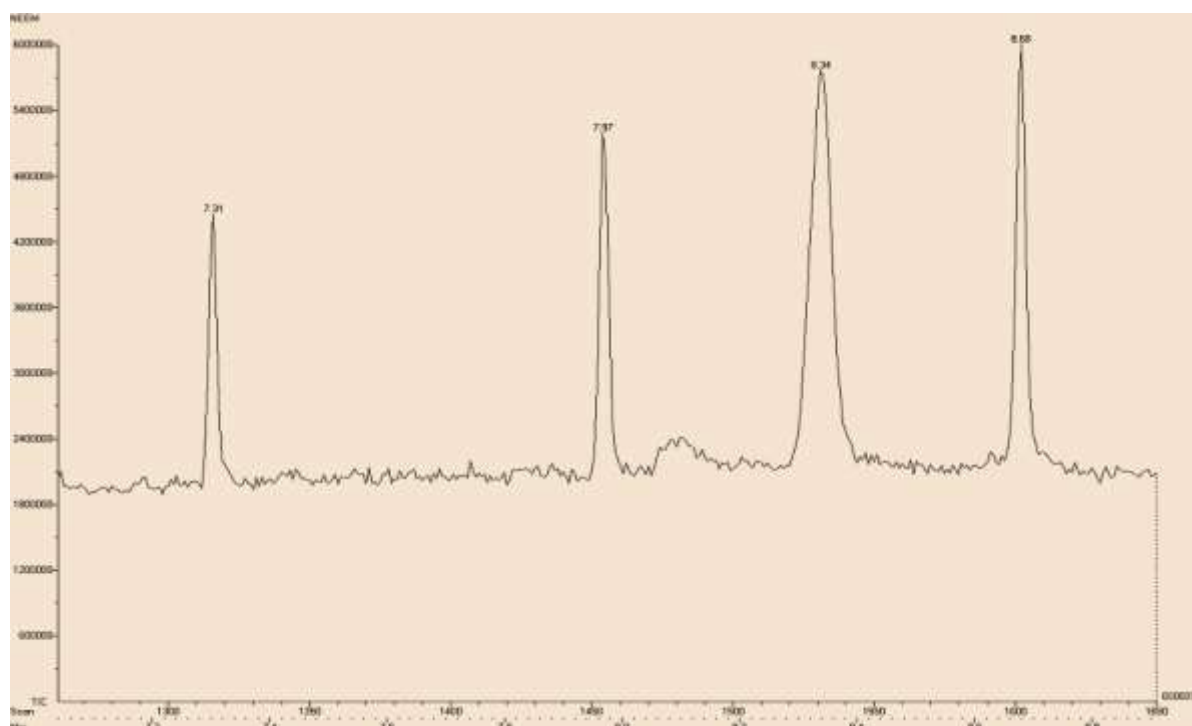
**Figure 1.** Mass spectrum of soya bean oil

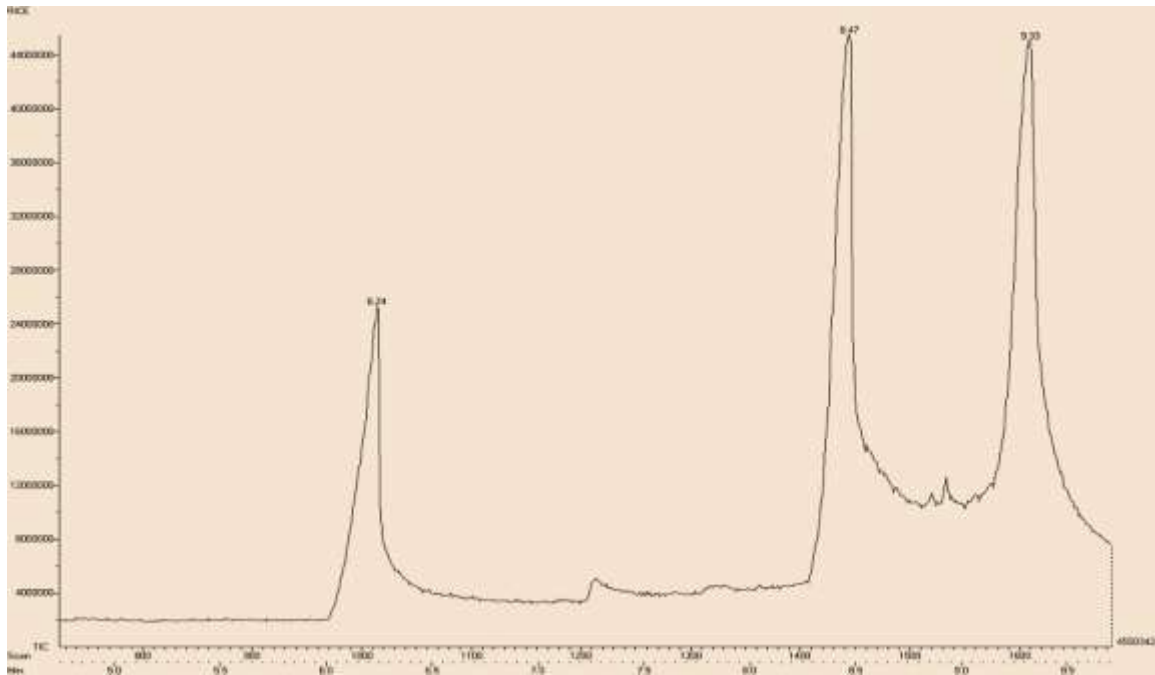

Figure 2. Mass spectrum of Rice bran oil

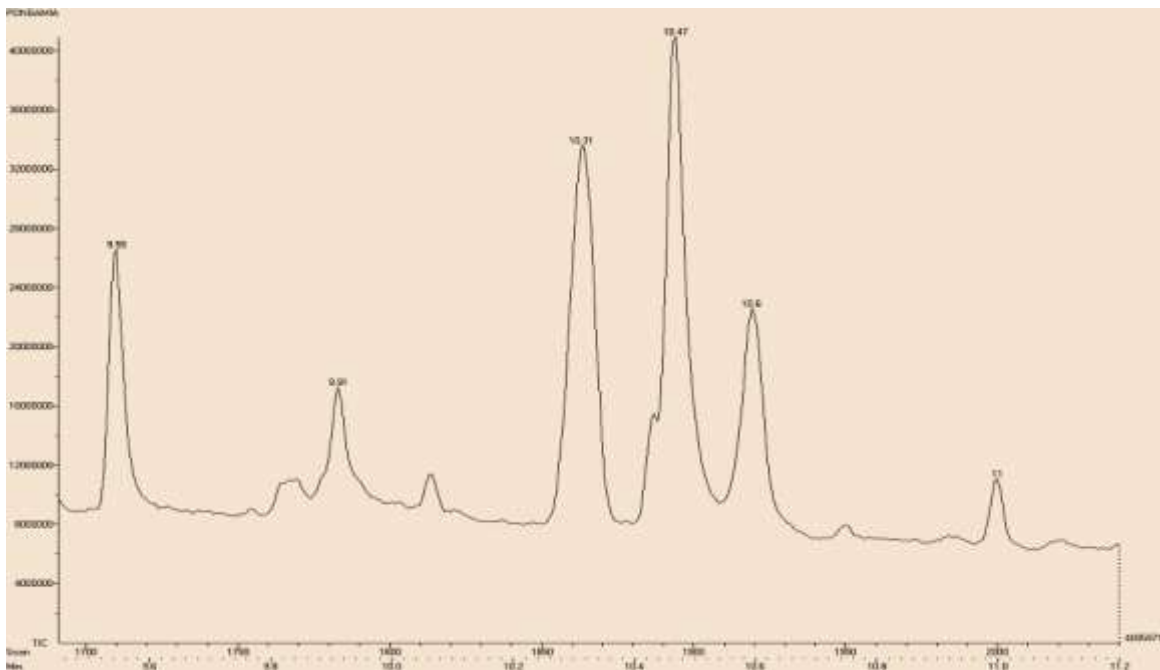

Figure 3. Mass spectrum of pongamia oil

2.GC/MS test analysis for soya bean, rice bran and pongamia fatty acids

The various biodiesels of soya bean, rice bran and pongamia fatty acids were identified using an averaged entire ion mass spectrum, samples obtained from cold pressed different oils analyzed using this method and the chromatograms were correlated against chromatograms attained from the lab. The details of the fatty acids and their retention time and their rates are summarized below GC/MS analysis was carried out using JEOL GC MATE 2 GC MS data system which is equipped with double focusing high resolution electron impact helium gas carried with a time range of 60 to 600 ionizations. JEOL GC MATE identified four major fatty acid esters namely Palmitic acid, Stearic acid, Oleic acid and Linoleic acid present in the soya bean, rice bran and pongamia biodiesels.

The base peak of the chromatogram is found for soya bean biodiesel at RT 8.68 with reference to McFaffarty rearrangement. Some minor and major peaks are also seen at RT7.31, RT 7.97, RT 8.34 and RT 8.68 as shown in Figure 1. The base peak of the chromatogram is found for rice bran biodiesel at RT 9.33 with reference to McFaffarty rearrangement. Some minor and major peaks are also seen at RT 6.24 and RT 9.33 as shown in Figure 2. The base peak of the chromatogram is found for pongamia biodiesel at RT 10.47 with mention to McFaffarty rearrangement. Some minor and major peaks are also seen at RT9.5, RT 10.31, RT 10.47 and RT 11 as shown in Figure 3.

3. Experimental procedure

The Direct fuel injection of Kirloskar DM10 type was used in this investigation and requirements were mentioned in Table 3.

Table 3 Requirement of the experiment compression ignition

Category of engine	Kirloskar DM10
Bore &	102 mm
Stroke	118 mm
Fuel Injection pressure	190-200 bars
speed	1500 Revolution Per Minutes
Compression ratio	17.5 : 1
Injection timing	26° Before Top Dead Center
Capacity	984 Cubic Capacity
Maximum power	10 Brake Horse Power

The outline of the engine experiment setup is exposed in Figure 4. The test engine was attached with Direct Current (DC) electrical dynamometer and investigational tested by different blends of oil methyl esters. The engine loads were analyzed between the low to maximum load condition such as 0% load to 80% load conditions respectively. The 40% and 80% load conditions are considered for experimental investigation based on the graph function. The stopwatch clock was utilized to take the time for fuel consumption of 10 Cubic Capacity and concern in the way of establishes the Specific Fuel Consumption. The orifice meter helps to analyze the mass flow rate of air and attached with manometer [16,17]. The pressure transducer type Kistler 701A was engaged to inspect the cylinder pressure deviations during combustion analysis. Multipurpose charge amplifier supports to amplify the combustion factors and exposed by data acquisition system. The half an hour of heat time was given before testing the every blends of Diesel/oil methyl esters [17]. The position of crake angle degree injection timings were changed by adding and removing the shim in between the timing gears of fuel injection pump as shown in Figure 5. The fuel injection pump is fitted with the number of thin strip of material for advanced and retarded the positions of injection timings. A thin strip of material was added in gears with the thickness of 0.325 mm to retard the injection timing by 9° and a thin strip of material of 0.290 mm thickness is removed from the original gear setting for advancing the injection timing by 9° CAD [18].

Hariram and Bharathwaaj, 2015

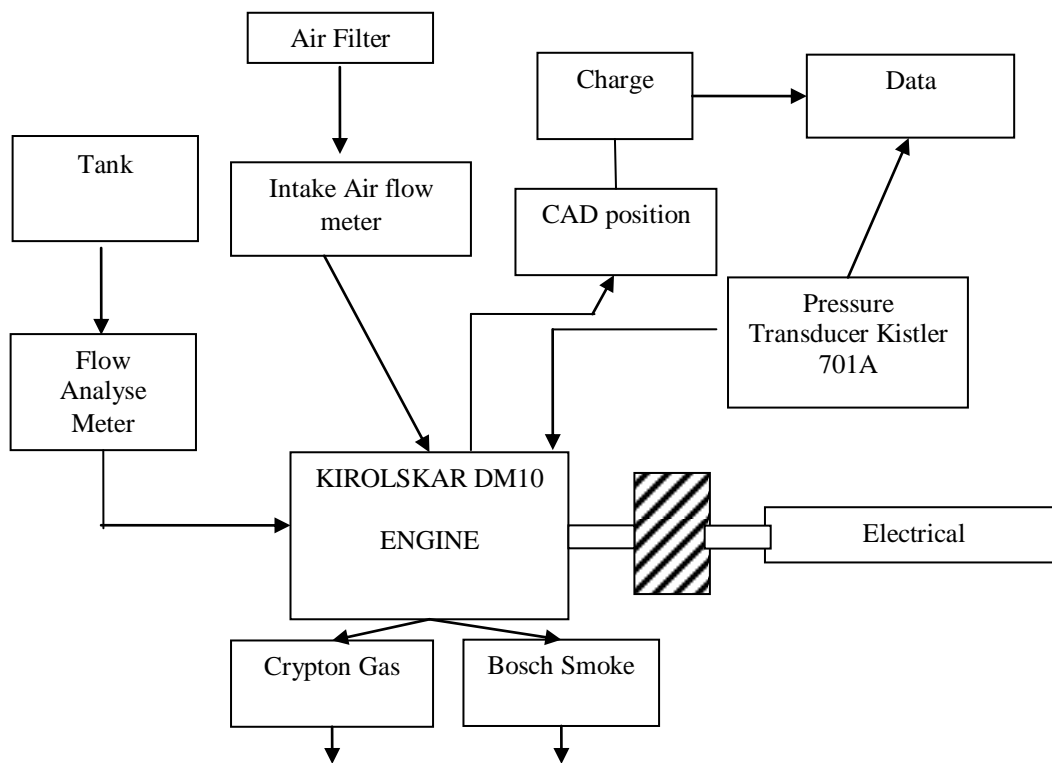

Figure.4 Proposed shape of experimental setup



Figure 5 Varying injection timings with shim concept

4. Results and discussion

4.1 Result of combustion pressure variation

The injection timings plays a very necessary role in affecting the combustion pressure variation at all load condition for different biodiesel blends under two different fuel injection timings. At 40% and 80% load measures, the valuation of combustion pressure ranges in cylinder at standard, advanced and retarded injection timings for different biodiesels. Various blend ratios of diesel and three different oil methyl esters were

investigated to demonstrates the various combustion pressure in bar with crank angle position. The observation of Figure 6 and Figure 7 describes that peak pressure range for SBO methyl esters have the pressure range in bars such as 59, 61 and 61.5 bars at 40% load measurements with standard injection timing (334 CAD) as well as RBO and PO methyl esters have the pressure range in bars like 62, 62.5, 63, 63.5, 64 and 66 bars respectively.

On advanced fuel injection timings, the start of combustion occurs very earlier than the standard crank position and the pressure curve attained the near vertical path towards the peak than standard injection timings combustion pressure. Advancing the injection timing has attained with help of gear tooth altered by 9° CAD position stands to enhance the fractions from 2 % to 4 % of pressure ranges as mentioned in bars such as 60, 62.5 and 63 bars for SBO methyl esters, 64, 64.5 and 65.5 bars in maintain of RBO methyl ester and 67, 69 and 72 bars in hold of PO methyl ester blends in that order at 80% load measurements. The Advanced injection timings possibly rooted with improved premixed combustion stage resulted owing to extensive time of ignition delay. Enhance the calorific values of the fuel that helps to improve the pressure range of 1% to 3% for PO methyl ester blends. At 40% and 80% load measurements, B15 ratio of PO methyl esters demonstrated 71.5 bars and 74 bar pressure rise in the cylinder core. The entire quantity of oil methyl esters blend ratios creates the maximum pressure in cylinder with variation of crank angle degree from 10° to 15° positions. The result of the crank angle variation specifies that the compression ignition is secured from detonation and improve the continuous life of the engine with all biodiesel blends. The variation in combustion pressure raise with advanced injection timing for SBO, RBO and PO methyl esters at partial and maximum load measurements. The results of the combustion peak pressure ranges were improved from 3% to 4% and the developments were happened by the reason of extended injection delay. The complete combustion process was attained due to enhanced pressure as exposed in Figure 8 and Figure 9. It proves that at no load and low load measurements, the combustion analysis of cylinder pressure raise for diesel and blends of SBO, RBO and PO methyl esters were approximately related by standard and advanced injection timing other than retarded timings demonstrated 1% to 3% decrease in cylinder pressure in combustion chamber.

The combustion factor analysis of pressure range variation for SBO, RBO and PO methyl esters on partial and maximum load measurements by included the injection timing of retardation position. The significant percentages from 4 to 6 negative progresses in peak pressure ranges are exposed in Figure 10 and Figure 11. The fuel is injected and establishes near to start of ignition that fact directs to more amount of fuel injected throughout the delay period with the variation of retardment position injection timing [19]. The lesser time of premixed combustion and shorter ignition delay were produced negative progress in peak pressure. Burning rate throughout preliminary stage of combustion was decreases as a result of shorter ignition delay. The conclusion of the result analysis showed that the pressure range increased from 3% to 5% with the blend ratio of B15. The different load measurements were utilized to produce the significant improvement in advancement of injection timing with 9° CAD position.

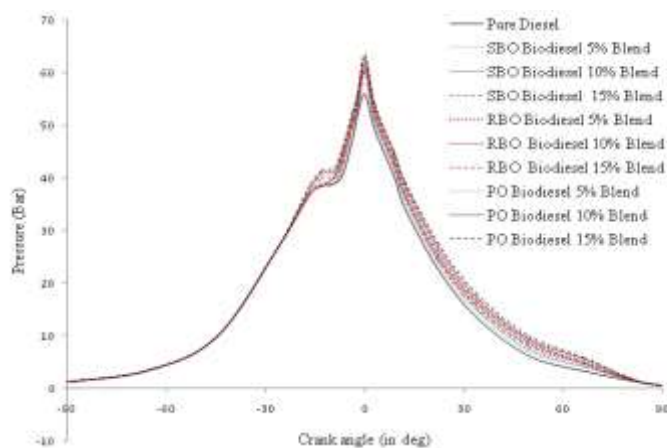

Figure. 6 Evaluation of combustion pressure range in Cylinder at 40 % load action for blends of various oil methyl esters with standard injection timing (334 CAD)

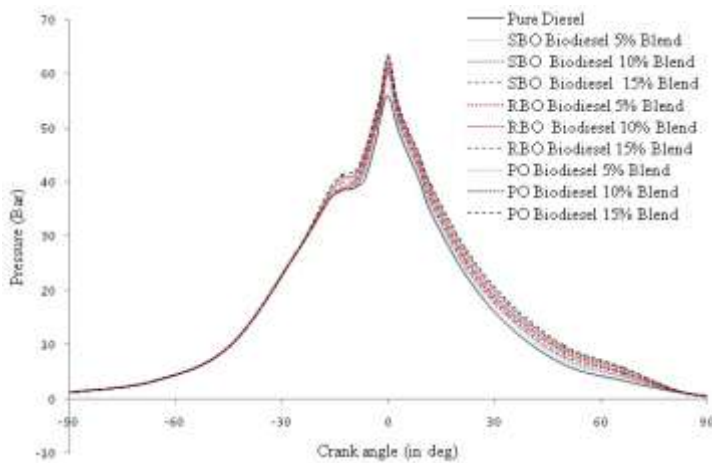

Figure.7 Evaluation of combustion pressure range in Cylinder at 80 % load action for blends of various oil methyl esters with standard injection timing (334 CAD)

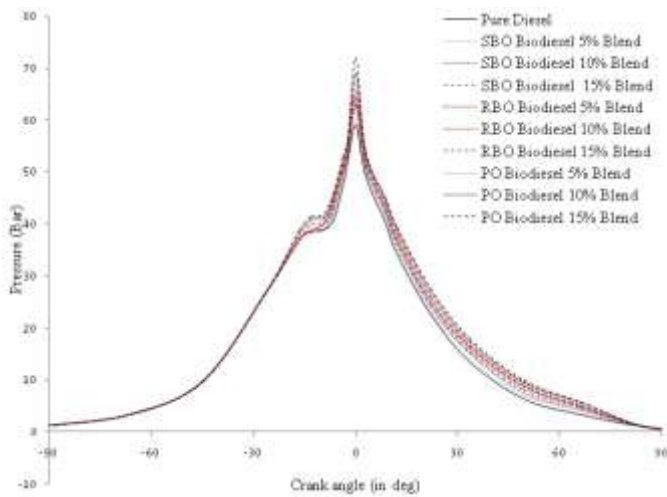

Figure.8 Evaluation of combustion pressure range in Cylinder at 40 % load action for blends of various oil methyl esters with advance injection timing (325 CAD)

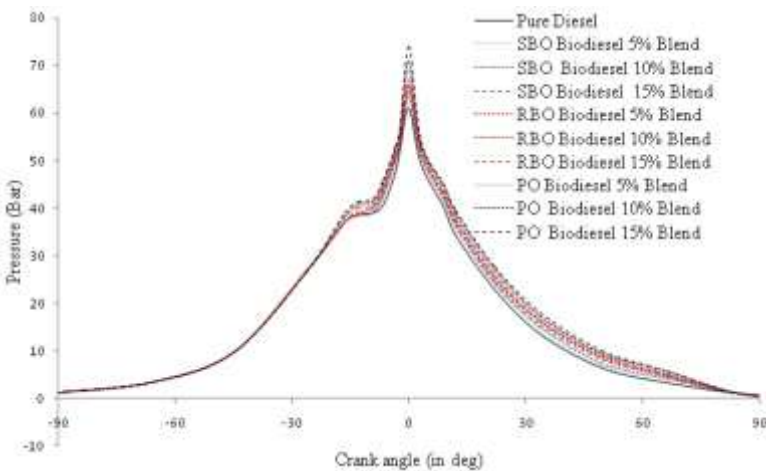

Figure. 9 Evaluation of combustion pressure range in Cylinder at 80 % load action for blends of various oil methyl esters with advance injection timing (325 CAD)

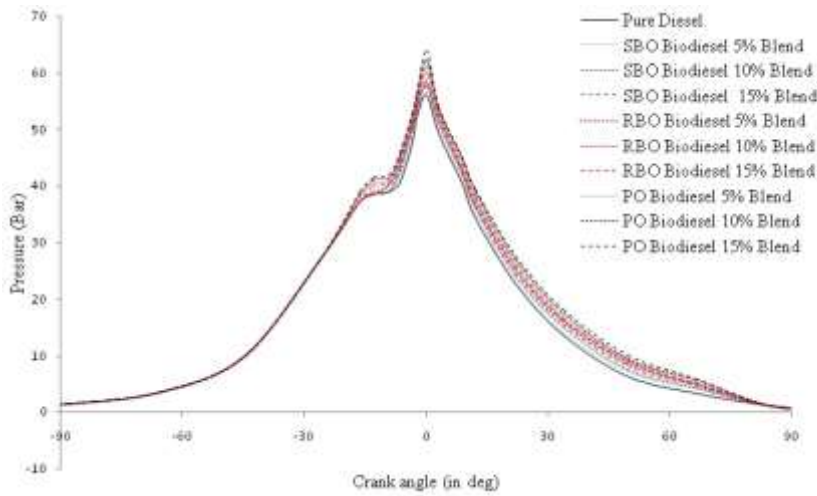

Figure. 10 Evaluation of combustion pressure range in Cylinder at 40 % load action for blends of various oil methyl esters with Retarded injection timing (343CAD)

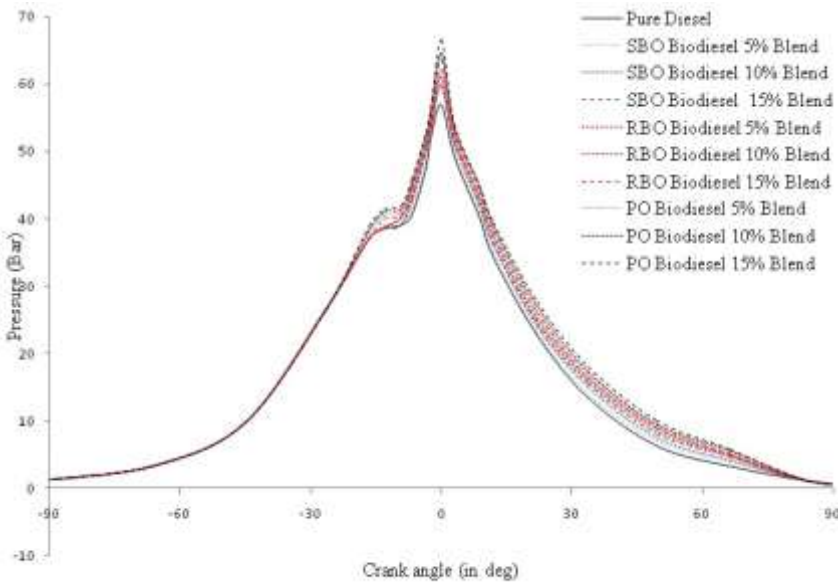

Figure. 11. Evaluation of combustion pressure range in Cylinder at 80 % load action for blends of various oil methyl esters with Retarded injection timing (343 CAD)

4.2 Result of Rate of Heat Generation(RHG)by combustion

Proportional outcomes of RHG by combustion at 80 % load measurements for SBO, RBO and PO methyl esters with 334 CAD, 325 CAD and 343CAD positions were exposed in Figure 12, Figure 13 and Figure13.RHGby combustion was measured by means of the theoretical Eq. (1).

$$\frac{(dQ_{ch})}{dt} = \frac{\gamma}{\gamma-1} P \frac{dV}{dt} + \frac{1}{\gamma-1} V \frac{dP}{dt} \tag{1}$$

In details that γ is the relation of Specific Heat in constant pressure to Specific heat in constant volume and proportion of dQ_{ch} toward dt be the overall heat release in kJ/deg CA, Instantaneous P considered as in-cylinder pressure and V described as volume throughout the extension process. Pressure transducer was adapted to indicate the combustion pressure intended for every 0.26 Crank Angle Degree position in 100 rotations and practiced in the direction of measure the heatgeneration by combustion. It is experiential to facilitate at 334

CAD position, the RHGby combustion was 3% to 4% higher for biodiesel blend ratios than diesel as exposed in **Figure 12**. At 334 CAD position injection timing, the ignition delay for SBO, RBO and PO methyl esters were established to be shorter than diesel. At 325 CAD position advanced injection timings had demonstrates that the perfect enhancement in RHGby combustion for biodiesels by 3% to 8%.Fuel was accrued into the cylinder chamber for longer period and duration for whole combustion development was offered through increasing the ignition delay by 325 CAD position injection timings as shown in **Figure 13**. The analysis of RHG by combustion was high for PO methyl esters on some injection timings and loads, fact that specifies high monovalent argon, is released during combustion and absolute ignition process is started.RBO methyl esters also demonstrates 1% to 3% improve in RHG by combustion but lesser that PO methyl esters as of lesser latent heat of vaporization and calorific rates. Injection timing of Retardment by 9 CAD for SBO, RBO and PO methyl esters blends are exposed in **Figure.14** which demonstrates reduce in RHG by combustion while assessed with injection timings of 334 CAD and 325 CAD positions because of comparatively shorter period of ignition delay and premixed combustion. Maximum blend of SBO, RBO and PO methyl esters demonstrates 1% to 4% advances in net RHG by combustion with injection timings of advancement position [20, 21].

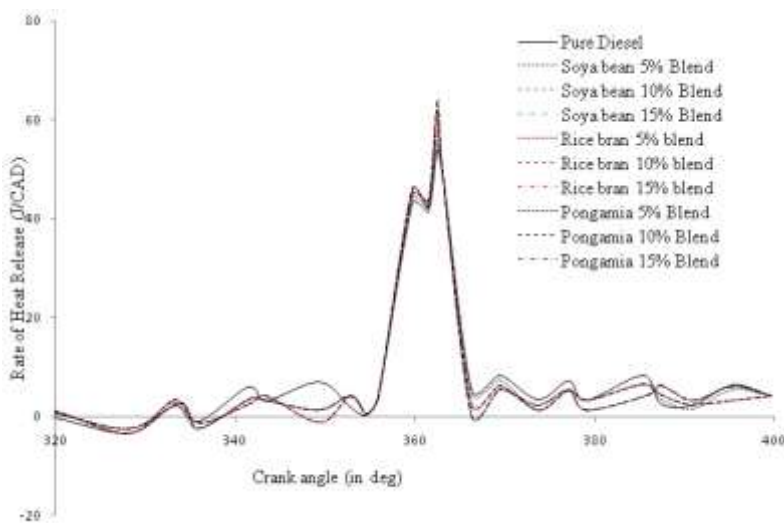

Figure.12 Evaluation of RHG by combustion at 80% load action for blends of SBO, RBO and PO methyl esters with Standard injection timing (334 CAD)

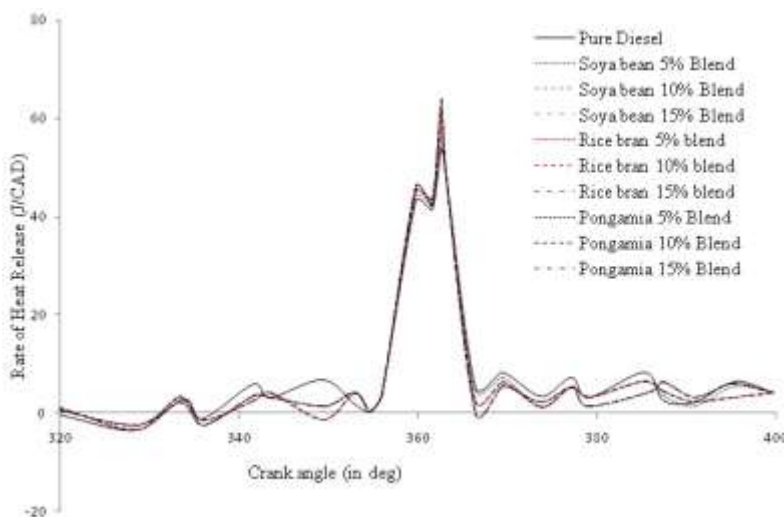

Figure. 13 Evaluation of RHGby combustion at 80% load action for blends of SBO, RBO and PO methyl esters with advanced injection timing (325 CAD)

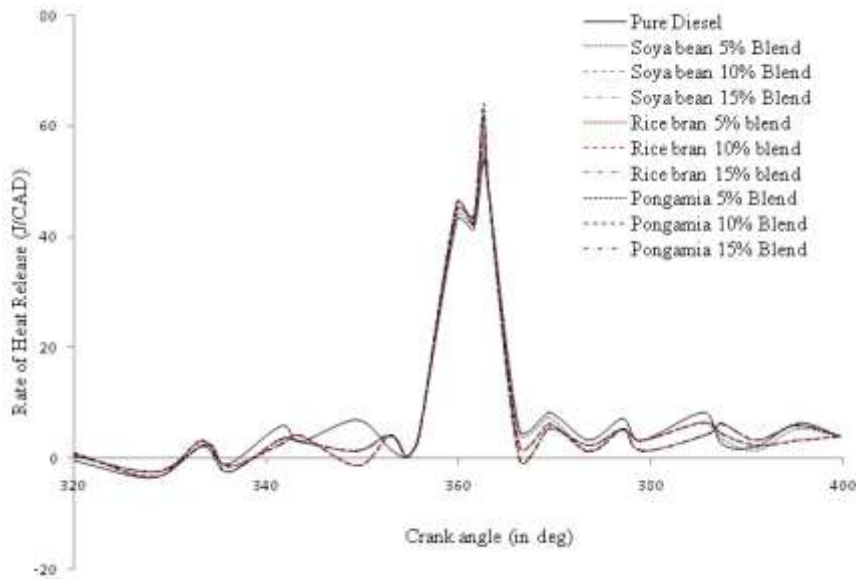

Figure. 14. Evaluation of RHG by combustion at 80% load action for blends of SBO, RBO and PO methyl esters with Retarded injection timing (343 CAD)

5. Conclusion

Result of different injection timings considered the practice of fatty acid methyl esters from SBO, RBO and PO methyl esters were evaluated on its combustion studies of pressure raise in cylinder core and RHG by combustion. The injection timings contribution was desired for RHG by combustion and improves thermal efficiency of the compression ignition engine. The injection timings of advancement by 9 CAD varied from the standard injection position of 334 CAD and modification of the injection procedure was utilized to develop the burning factor of RHG by combustion with every biodiesel blends. Injection timings of Advancement position had produced 4% to 6% enhance in maximum pressure raise in the cylinder by higher blends of pongamia methyl ester. Two different methyl esters of RBO and PO demonstrated 2% to 4% increase in the pressure range. The result of ignition delay of longer period and concentrated combustion stage of premixed reaction with RHG by combustion. The heat release investigation of RHG by combustion process and it has explained 4% to 7% improved than diesel fuel with blend amounts of RBO and PO methyl esters. The standard Injection timings of 343 CAD position implemented in the way of displaying the proportion of 3% to 4% pessimistic progress that 334 CAD position injection timings for all blend ratios over every load measurements.

Reference

1. Venkanna, BK & Venkataraman Reddy, C 2015, 'Performance, emission, and combustion characteristics of a diesel engine running on blends of honne oil and diesel fuel', International Journal of Green Energy, vol. 12, pp.728–736.
2. Gnanamoorthi, V & Devaradjane, G 2015, 'Effect of compression ratio on the performance, combustion and emission of DI diesel engine fueled with ethanol-Diesel blend', Journal of the Energy Institute, vol. 88, pp.19-26.
3. Serin, H & Akar, NY 2014, 'The performance and emissions of a diesel engine fueled with tea seed(*Camellia sinensis*) oil biodiesel/diesel fuel blends', International Journal of Green Energy, vol. 11, pp.292–301.
4. Amit B. Solanki, CharulaH.Patel, Abhishek, Y& Makawana 2014, 'Design Analysis and Optimization of Hybrid Piston for 4 stroke Single Cylinder 10 HP (7.35 kW) Diesel Engine', International Journal of Engineering Trends and Technology, vol.16,pp.258-262.
5. Vaishali, R & Khamankar, SD 2015, 'Stress analysis of piston using pressure load and thermal load', International Journal of Mechanical Engineering, vol.3, no. 8, pp.1-8.

6. Cerit, M, Ayhan, V, Parlak, A & Yasar, H 2011, 'Thermal analysis of a partially ceramic coated piston: Effect on cold start HC emission in a spark ignition engine', *Applied Thermal Engineering*, vol. 31, pp.336-341.
7. EkremBuyukkaya & Muhammet Cerit 2007, 'Thermal analysis of a ceramic coating diesel engine piston using 3-D finite element method', *Surface & Coatings Technology*, vol.202, pp.398-402.
8. Muhammet Cerit 2011, 'Thermo mechanical analysis of a partially ceramic coated piston used in an SI engine', *Surface and Coatings Technology*, vol.205, pp. 3499-3505.
9. Jindal, S 2010, 'Effect of engine parameters on NOx emissions with Jatropha biodiesel as fuel', *International journal of Energy and Environment*, vol. 1, no.2, pp.343-350.
10. Gharehghani, A, Mirsalim, M & Hosseini, R 2017, ' Effects of waste fish oil biodiesel on diesel engine combustion characteristics and emission', *Renew Energy*, vol. 101, pp.930-936.
11. Salamanca, M, Mondragon, F, Agudelo, JR, Benjumea, P & Santamaria, A 2012, 'Variations in the chemical composition and morphology of soot induced by the unsaturation degree of biodiesel and a biodiesel blend', *combustion and flame*, vol. 159, no. 3, pp. 1100-1108.
12. Benjumea, P, Agudelo, JR & Agudelo, AF 2011, 'Effect of the degree of unsaturation of biodiesel fuels on engine performance, combustion characteristics, and emissions', *Energy and Fuels*, vol. 25, no.1, pp. 77- 85.
13. Knothe, G & Razon, LF 2017, 'Biodiesel fuels', *Progress in Energy and Combustion Science*, vol. 58,pp.36-59.
14. Hao Yang, Xing-Hu Li, Ming-Fei Mu & Gui-Yue Kou 2017, 'Comparative Performance and Emissions Study of a Direct Injection Diesel Engine Using Diesel Fuel and Soybean Biodiesel', *Journal of Applied Science and Engineering*, vol. 20, no. 2, pp. 201-210.
15. Jayaprabakar, J, Karthikeyan, A & Ramesh kumar, V 2017, 'Effect of injection timing on the combustion characteristics of rice bran and algae biodiesel blends in a compression-ignition engine', *International Journal of Ambient Energy*, vol.38, no.2, pp.116-121.
16. Sivakumar, Muthusamy, Nallathambi Shanmuga Sundaram, Ramasamy Ramesh kumar & Mohamed Hussain Syed Thasthagir 2018, 'Effect of Aluminium Oxide Nanoparticles Blended Pongamia Methyl Ester on Performance, Combustion and Emission Characteristics of Diesel Engine', *Renewable Energy*, vol. 116, pp. 518-526.
17. Perumal, Varatharaju & Ilangkumaran, M 2017, 'Experimental Analysis of Engine Performance, Combustion and Emission Using Pongamia Biodiesel as Fuel in CI Engine', *Energy*, vol. 129, pp. 228-236.
18. Satyanarayana, K, Uma Maheswara Rao, SV, Viswanath, AK & Hanumanta Rao, TV 2018, 'Quasi-dynamic and thermal analysis of a diesel engine piston under variable compression', *Materials Today: Proceedings*, vol.5,pp. 5103-5109.
19. Kapil Dev Choudharya, Ashish Nayyarb & Dasguptaa, MS 2018, 'Effect of compression ratio on combustion and emission characteristics of C.I. Engine operated with acetylene in conjunction with diesel fuel', *Fuel*, vol.214, pp.489-496.
20. Dhananjay Kumar Srivastava1 & Avinash Kumar Agarwal 2018, 'Combustion characteristics of a variable compression ratio laser-plasma ignited compressed natural gas engine', *Fuel*, vol. 214, pp. 322-329.
21. How, HG, Masjuki, HH, Kalam, MA & Teoh, YH 2018, 'Influence of injection timing and split injection strategies on performance, emissions, and combustion characteristics of diesel engine fueled with biodiesel blended fuels', *Fuel*, vol. 213, pp.106-114.
