

Hydrogen Synthesis from Solar Reactor using Reverse Photosynthesis

K.Kanimozhi ¹, B. Raja Mohamed Rabi ²

¹Dept. of Electrical & Electronics Engineering, Sethu Institute of Technology
Pullor, Tamilnadu, India

²Dept. of Mechanical Engineering, Sethu Institute of Technology
Pullor, Tamilnadu, India

Abstract : In this paper a review of synthesis of hydrogen from solar energy is discussed. The analysis reports on Photovoltaic (PV) research, accomplishment and recommendations of electrolysis, photoelectrochemical hydrogen production and photoelectrochemistry technology status. The potential of solar reactor construction in India is shown with the maps, which show the yearly sum of horizontal global irradiation of solar energy. The cost of electricity from solar technologies remains too high to achieve widespread deployment of solar-derived hydrogen. A solar gas power plant is proposed in this paper. Photovoltaic technology will be attractive as a potential source of electricity if the target price of electricity for utility applications is achieved.

Key words: solar energy, electrolysis, photovoltaic (PV) array, photoelectrochemical (PEC) splitting of water, photoelectrochemistry, European solar radiation database.

Introduction

There are several sources for producing hydrogen from renewable sources. These are listed in Table 1[1,2]. Solar and wind energy are two technologies that are commercially available to provide electricity for electrolysis. The cost of electricity is a significant portion of the cost of making hydrogen with electrolysis. The production of hydrogen through electrolysis from solar and wind energy is not currently cost-competitive because of high electricity cost (relative to grid electricity at today's bulk electricity prices) and because electrolyzers require further development.

Table 1: Sources of Hydrogen Production from Renewable Energy Sources

Source	Distributed Hydrogen Production	Centralized Hydrogen Production
Wind - based electrolysis	yes	yes
Geothermal - based	yes	yes
Hydropower - based	yes	yes
Biomass	yes	yes
Solar based electrolysis	yes	yes
Solar photoelectrochemical	yes	yes
Solar photobiological		yes
Solar thermochemical		yes

Different development models for near- and long-term hydrogen production and delivery to supply fuel for transportation range between distributed hydrogen production at fueling stations and centralized hydrogen production to supply fuel to many stations. The distributed model requires electricity at each station for electrolysis, where an electrolyzer making for example 1500 kg of hydrogen per day could produce enough hydrogen to refuel 300 cars each day [3]. This electricity is generally assumed to be delivered via the electric transmission and distribution grid, but it can also be generated on site by solar or wind equipment. The advantages of on-site electricity generation include reduced electrical distribution requirements and system efficiency improvements.

However, opportunities for on-site electricity generation are limited by resource availability and land-use restrictions. The advantage of distributed hydrogen production is that it avoids the large investment required to install a hydrogen delivery infrastructure by using existing or upgraded electrical transmission. Therefore, the distributed strategy is a possible option for transitioning to a hydrogen economy when market penetration is relatively small and doesn't justify large infrastructure investments. A possible variation of the distributed model is location of larger electrolyzers at production sites serving urban centers but separate from fueling stations, such sites near electrical substations, and delivering hydrogen to refueling stations via a local pipeline network or tube trailers. Benefits of this approach relative to production at fueling stations may include lower production costs from larger electrolyzers, improved ability to coordinate and optimize operations with electric service providers, and avoiding need for large electrical distribution service capacity upgrades and electrolyzer siting at fueling stations having limited space.

In this paper the different conventional methods for hydrogen synthesis are discussed i.e. Electrolytic hydrogen production, Photovoltaic electrolyzer system and Photoelectrochemical Hydrogen Production. Finally a solar gas power plant is proposed and its merits are discussed.

Electrolytic Hydrogen Production

Electrolysis is a process for breaking water (H₂O) into its constituent elements hydrogen (H₂) and oxygen (O₂) — by supplying electrical energy. An electric current is passed through an anode and a cathode in contact with water (Figure 1). The net reaction which occurs is:

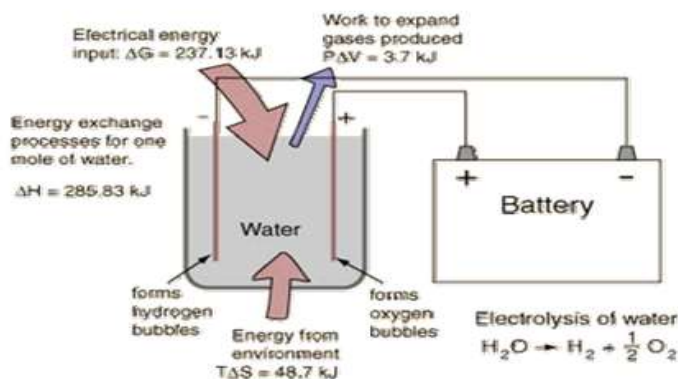
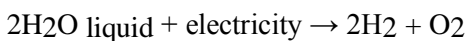

Figure 1: Electrolysis scheme

This reaction requires 39 kWh of electricity to produce 1 kilogram of hydrogen at 25 °C, and 1 atmosphere. Of the various procedures for the production of hydrogen from water, electrolysis is presently, and for the foreseeable future, the only one of practical importance. Although water electrolysis in its conventional form, i.e. alkaline electrolysis, electrolysis has only accounted for a very small proportion (0,1 – 0,2 %) of the world's direct hydrogen production, and this mainly in connection with low-cost hydro power production. Electrolysis has been in commercial use for over 80 years, The advantage of this process is that it can produce a

very clean hydrogen fuel that is free from carbon- and sulfur-based impurities, which can poison fuel cells.

Distributed electrolysis may play a role in the transition to the hydrogen economy when the demand for hydrogen is small but growing and there is little delivery infrastructure for hydrogen. Some electrolysis processes are specifically optimized for hydrogen production. The low pressure electrolysis method is a well-proven industrial technology, and two processes (high-pressure and high-temperature electrolysis) are still in the development phase.

Electrolytic hydrogen production serves a high-value industrial and chemical market. The keys to adapting this technology to meet energy-related applications in the future are reducing cost and enhancing performance. Alkaline is the most mature and is the current technology for most commercial systems in use today. Although PEM electrolysis systems are still higher cost, they are expected to mirror the cost reduction and improvements for fuel cells. Today these electrolyzers have relatively high energy efficiencies themselves. The cost of hydrogen depends on the cost of electricity as well as the capital cost of the electrolyzer systems and their operating efficiency.

Table 2: Range of Energy Efficiencies for Today's Electrolysis Systems

Alkaline HHV* Efficiency %	PEM HHV* Efficiency, %
57 - 75	56 - 70

* HHV is Higher Heating Value

Other reports quote the theoretical maximum efficiency of electrolysis, which is between 80 – 94% [4]. One opportunity to reduce the cost of hydrogen produced by electrolysis is to replace part of the electricity requirement with heat, achieving higher overall energy efficiency. Concentrated solar energy and high temperature nuclear could supply sufficient heat to reduce the electrical requirement. Such systems are not in operation today, and would require solid oxide or other higher temperature electrolyzers.

Recent accomplishments in the electrolysis area include hydrogen production in a planar electrolysis stack at 2,000 psi (requires less compression energy), development of a new electrolysis system design with 50% part count reduction, and development of low-cost alkaline and PEM electrolysis systems for high pressure operation. A PEM electrolyzer stack has been installed and tested under variable operation to simulate renewable electricity source impacts. It is expected :

1. Continuing research on electrolyzer materials to lower cost.
2. Continuing work on systems integration and optimization of wind turbine and electrolyzer systems.
3. Conducting limited demonstrations of renewable-energy electrolysis systems when research targets in technology roadmaps have been verified.

Photovoltaic Electrolyzer System

The photovoltaic / electrolyzers system usually consists of the following major components (see Figure 2) : PV array which is made of several units; a maximum power point tracker (MPPT); a DC-DC converter, which is used to operate the system at the maximum power of the photovoltaic system at all times and to supply the necessary DC current to the electrolyzer ; an industrial electrolyzer system and a storage system for hydrogen[5].

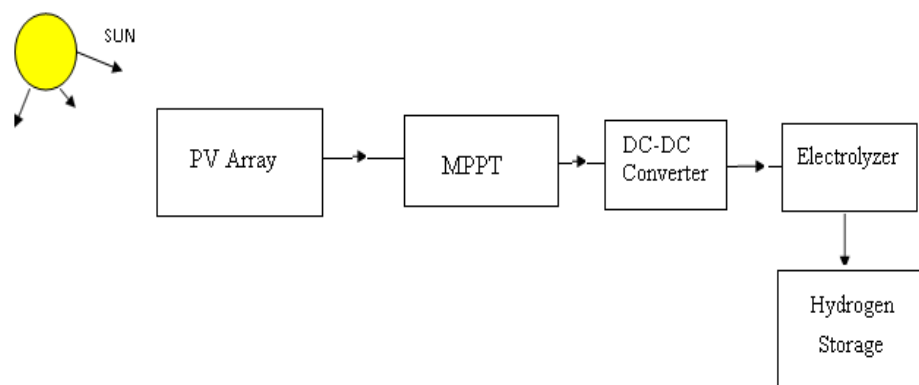

Figure 2 : Schematic of PV – hydrogen production system

One of the main efforts of R&D worldwide is to reduce the costs of solar technologies. The research programmes in European countries fund new developments with respect to material use and consumption, device design, reliability and production technologies as well as new concepts to increase the overall efficiency[6]. The US DOE Solar Program is currently pursuing the development of three generations of photovoltaic (PV) devices: discrete wafers of crystalline silicon, thin-film materials amenable to rapid manufacturing methods, and band gap-engineered materials and novel quantum mechanical approaches (e.g., Periodic Table Group III-V materials, multijunctions, polymer cells, quantum dot sensitized nanoparticle materials). The long range 2020 goals of the program are to achieve lesser costs for residential systems, commercial systems, and for utility applications. These values assume a grid-tied, battery-free, fully installed photovoltaic system.



Figure 3 : Installed PV array

For the PV-electrolyzer combination to be competitive in the future, either the cost of PV modules has to be reduced by an order of magnitude from current costs, or the electrolyzers' cost has to come down substantially from the low cost of \$125/kW already assumed in the committee's future technology case. A factor contributing to this need for low electrolyzer cost is the low utilization of the electrolyzer capital (solar energy is taken to be available 20 percent of the time). Therefore, while electricity at \$0,098/kWh from a PV module can be quite attractive for distributed applications in which electricity is used directly at the site, hydrogen costs via PV-electricity and electrolysis will not be competitive. Energy is consumed in the manufacture of solar modules. It has been estimated by the National Renewable Energy Laboratory (NREL) in the USA, that for a crystalline silicon module, the payback period of energy is about 4 years. For amorphous silicon modules this period is currently around 2 years, with the expectation that it will eventually be less than 1 year [7].

Photoelectrochemical Hydrogen Production

The direct photoelectrochemical (PEC) splitting of water is a one-step process for producing hydrogen using solar irradiation; water is split directly upon illumination. The basic photoelectrochemical device consists of a semiconductor material immersed in an aqueous solution configured such that it can be illuminated by direct sunlight. Photoelectrochemical devices combine solar PV and electrolysis into a single monolithic device. This provides the possibility of higher conversion efficiency and lower cost for solar-driven hydrogen generation from water as compared to standard PV/electrolysis.

PEC hydrogen production is in an early stage of development; therefore, the current hydrogen cost cannot be accurately assessed. Its future depends on a breakthrough in developing photoelectrochemical materials that are durable and efficient in producing hydrogen. Known light-absorbing semiconductor materials have either low efficiency (1%-2%) or low durability in a liquid electrolytic environment.

Research is progressing to:

Study high-efficiency materials and low-cost, durable materials to attain the basic scientific understanding that will be needed to integrate the necessary functionality into a single material.

Develop multijunction devices that incorporate multiple material layers to achieve efficient water splitting.

Methods of manufacturing these systems also need to be developed in conjunction with the materials and device research. The basic structure of a photoelectrode is shown in the Figure 4.

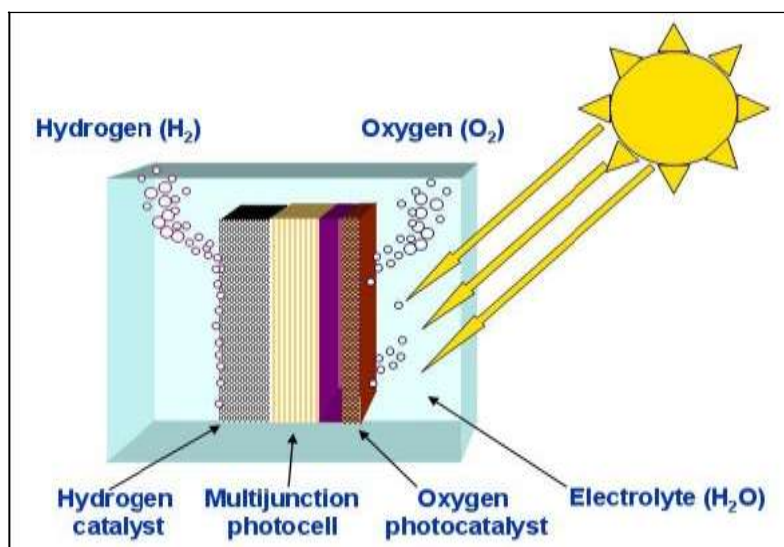

Figure 4: Basic structure of a Photoelectrode

Potential of Solar Energy in India

Hydrogen can be produced from solar resources throughout the country. During the years 2001–2005, an Indian solar radiation database was developed using a solar radiation model and climatic data was integrated. The database, with a resolution of 1 km × 1 km, consists of monthly and yearly averages of global irradiation and related climatic parameters. The database has been used to analyze regional and national differences of solar energy resource and to assess the PV potential. The calculation of electricity generation potential by contemporary PV technology is a basic step in analyzing scenarios for the future energy supply and for a rational implementation of legal and financial frameworks to support the developing industrial production of PV[8]. Figure 5 shows the solar resource capacity available in India. From this figure Gujarat and Rajasthan are identified as best places for solar reactor construction.

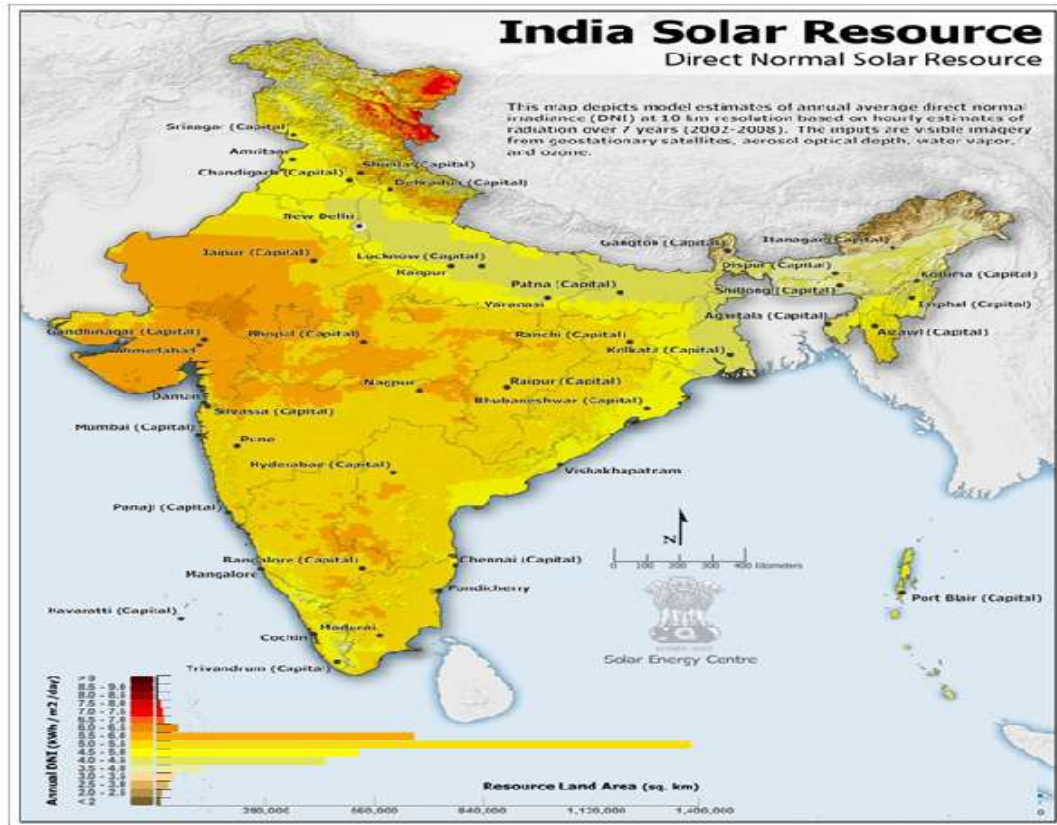

Figure 5 : Potential Sites for Solar energy

Hydrogen requirement estimate

A rough estimate for hydrogen requirement of a small car powered by hydrogen-fuel cell could be done based on published information on prototype vehicles [9]. For example, five passenger fuel cell powered Honda FCX (Stack)'s published characteristics show that the hydrogen consumption/range is 4.6 kg hydrogen/395 km range. If we assume 12,000 km driving per year, the annual hydrogen consumption will be 140 kg or using HHV of hydrogen about 20 GJ. This may be generated by using about 6900 kWh electricity if a 80% efficient electrolyzer is used. It is obvious that either of the renewable energy sources discussed in item can be used for this purpose.

Benefits of Solar Gas

A proposed solar gas power plant is shown in figure 6. The technology is well suited to local deployment leading to job creation through the local manufacturing and operation of the technology. The technology could provide improved energy and food security through reduced consumption of natural gas for the production of hydrogen and reduced risk to future increase in natural gas costs. The consumption of less natural gas per unit of hydrogen produced enables greater yields of fertilizer from existing natural gas infrastructure, and reduces carbon emissions. The potential for lower cost hydrogen production could lead to lower cost fertilizer for the agricultural sector by reducing feedstock costs.

The technology could reduce hydrogen production costs for other users such as petrochemical companies. Gujarat and Rajasthan were identified as key states for the application of the technology due to excellent solar resource, existing natural gas infrastructure and existing major industrial users of hydrogen in the petrochemical and fertilizer industries.

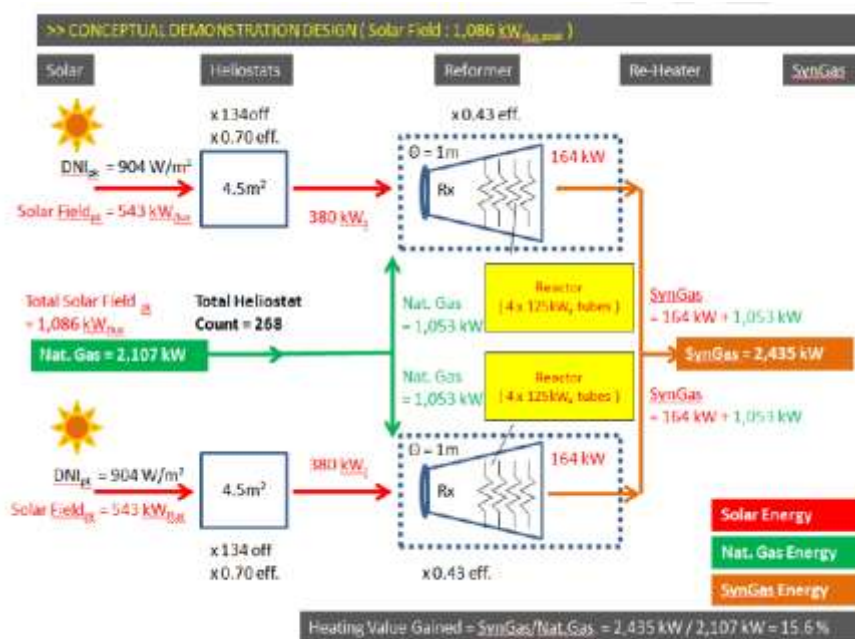

Figure 6 : Proposed solar Gas Power Plant

Conclusion

There are financial, technical, and environmental barriers facing the use of solar energy to meet hydrogen targets. Initial analysis results indicate the electricity costs will be a major price contributor to the price of hydrogen produced via electrolysis. The cost of electricity from solar technologies remains too high to achieve widespread deployment of solar-derived hydrogen. The current electricity cost of Solar PV technology ranges from 16 to 32 Rs./KWh depending on the market application. PV technology will be attractive as a potential source of electricity if the target price of electricity (5-7 Rs./KWh) for utility applications is achieved. With sufficient electrical transmission capacity, and lower capital costs for electrolyzers, hydrogen's competitiveness with gasoline will improve. The other three solar pathways — thermochemical, photoelectrochemical, and photobiological — would have similar or possibly higher productivity per unit of land area. However, the infrastructure is not in place, and the majority of the solar resources are located outside urban areas. The distribution and storage of hydrogen from point of generation to point of use will be key to economic, energy, and environmental impacts. Solar energy could play an important role in the hydrogen energy future, along with nuclear energy, coal with sequestration, biomass, and other renewables. All of these technologies require research and development to overcome technical and economic barriers to commercialization and economic production of hydrogen.

References

1. Steinfeld A, & Meiers A. Solar fuels and materials. In: Encyclopedia of energy, 2004,5;1192-1199.
2. Mohammad Reza Maghami, Shahin navabi asl, Mohammad esmaeil Rezadad, Nader Ale Ebrahim, and Chandima Gomess. Qualitative and quantitative analysis of solar hydrogen generation literature from 2001 to 2014, Scientometrics, 2015, 105; 759-771.
3. Christian Sattler, Ruth Klüser. Solar Hydrogen Production by a Two-Step Cycle Based on Mixed Iron Oxides, Journal of Solar Energy Engineering, 2006, 128; 125-133.
4. Alexander Tremel, Peter Wasserscheid, Manfred Baldauf. Liquid fuel synthesis based on hydrogen production via electrolysis, In proceedings of 20th World Hydrogen Energy Conference 2014, At Gwangju, Korea, 896-901.
5. Jieyang Jia, Linsey, Seitz, Jesse D. Benck, Yijie Huo, Thomas F. Solar water splitting by photovoltaic-electrolysis with a solar-to-hydrogen efficiency over 30%, Nature Communication, 2016, 7; 132-137.

6. Montoya JH, Seitz LC, Chakthranont P, Vojvodic A, Jaramillo TF, Nørskov JK. Materials for solar fuels and chemicals. *Natural Materials*,. 2016 ,16 ;70-81.
7. McCrory CC, Jung S, Ferrer IM, Chatman SM, Peters JC, Jaramillo TF..Benchmarking hydrogen evolving reaction and oxygen evolving reaction electrocatalysts for solar water splitting devices. *Journal of American Chemical Society*, 2015 ,137;4347-4357.
8. Harendra Kumar Yadav, Vijay Kumar, Vinay Yadav. Potential of Solar Energy in India: A Review, *International Advanced Research Journal in Science, Engineering and Technology* ,2015,2;63-66.
9. Paul Wolfram , Nic Lutsey. Electric vehicles: Literature review of technology costs and carbon emissions, *International Journal on clean transportation*,2016,1-9.
